

## KBPC2500W - KBPC2510W

## SILICON BRIDGE RECTIFIERS

PRV : 50 - 1000 Volts

Io : 25 Amperes

### FEATURES :

- \* High current capability
- \* High surge current capability
- \* High reliability
- \* Low reverse current
- \* Low forward voltage drop
- \* Pb / RoHS Free

### MECHANICAL DATA :

- \* Case : Metal Case
- \* Epoxy : UL94V-O rate flame retardant
- \* Terminals : plated .25" (6.35 mm). Faston
- \* Polarity : Polarity symbols marked on case
- \* Mounting position : Bolt down on heat-sink with silicone thermal compound between bridge and mounting surface for maximum heat transfer efficiency.
- \* Weight : 22.98 grams (approximately)

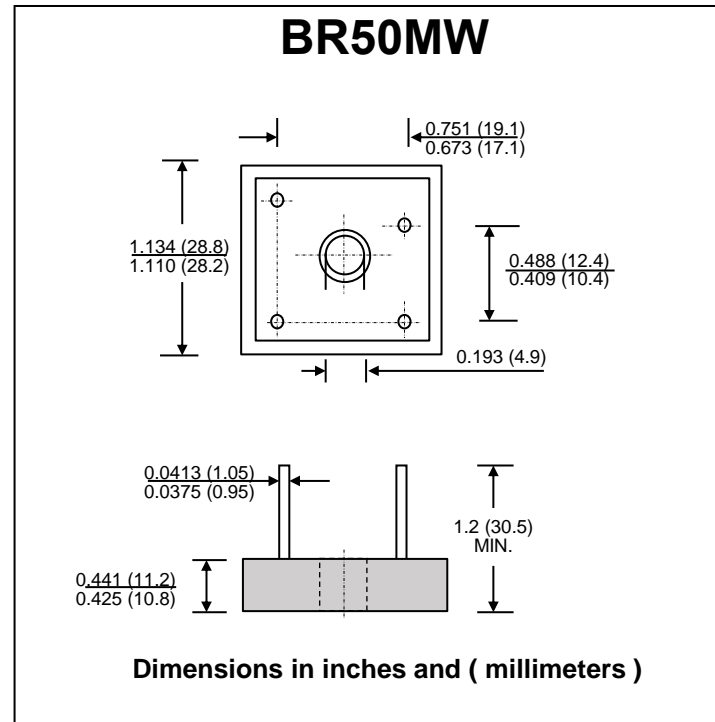

### MAXIMUM RATINGS AND ELECTRICAL CHARACTERISTICS

Rating at 25 °C ambient temperature unless otherwise specified.

Single phase, half wave, 60 Hz, resistive or inductive load.

For capacitive load, derate current by 20%.

RATING	SYMBOL	KBPC 2500W	KBPC 2501W	KBPC 2502W	KBPC 2504W	KBPC 2506W	KBPC 2508W	KBPC 2510W	UNIT
Maximum Recurrent Peak Reverse Voltage	V <sub>RRM</sub>	50	100	200	400	600	800	1000	V
Maximum RMS Voltage	V <sub>RMS</sub>	35	70	140	280	420	560	700	V
Maximum DC Blocking Voltage	V <sub>DC</sub>	50	100	200	400	600	800	1000	V
Maximum Average Forward Current T <sub>c</sub> = 55°C	I <sub>F(AV)</sub>	25							A
Peak Forward Surge Current Single half sine wave Superimposed on rated load (JEDEC Method)	I <sub>FSM</sub>	300							A
Current Squared Time at t < 8.3 ms.	I <sup>2</sup> <sub>t</sub>	375							A <sup>2</sup> S
Maximum Forward Voltage per Diode at I <sub>F</sub> = 12.5 A	V <sub>F</sub>	1.1							V
Maximum DC Reverse Current Ta = 25 °C at Rated DC Blocking Voltage Ta = 100 °C	I <sub>R</sub>	10							μA
	I <sub>R(H)</sub>	200							μA
Typical Thermal Resistance (Note 1)	R <sub>θJC</sub>	1.45							°C/W
Operating Junction Temperature Range	T <sub>J</sub>	- 40 to + 150							°C
Storage Temperature Range	T <sub>STG</sub>	- 40 to + 150							°C

#### Note :

1. Thermal Resistance from junction to case with units mounted on a 5" x 6" x 4.9" (12.8cm.x 15.2cm.x 12.4cm.) Al.-Finned Plate

**RATING AND CHARACTERISTIC CURVES (KBPC2500W - KBPC2510W)**

**FIG.1 - DERATING CURVE FOR OUTPUT RECTIFIED CURRENT**

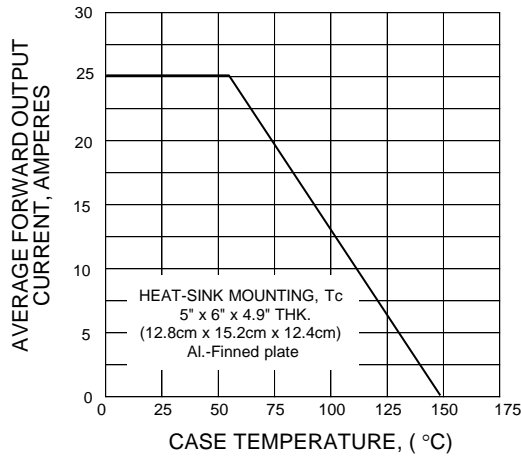

**FIG.2 - MAXIMUM NON-REPETITIVE PEAK FORWARD SURGE CURRENT**

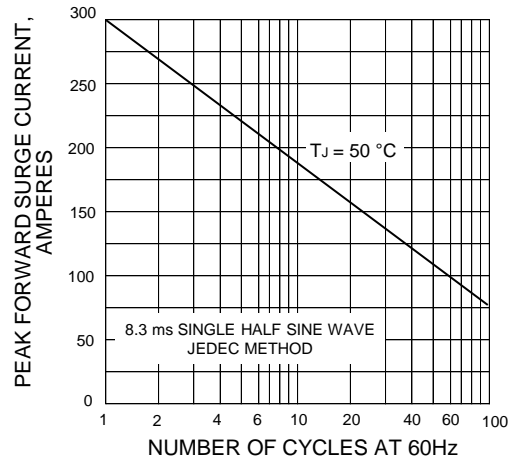

**FIG.3 - TYPICAL FORWARD CHARACTERISTICS PER DIODE**

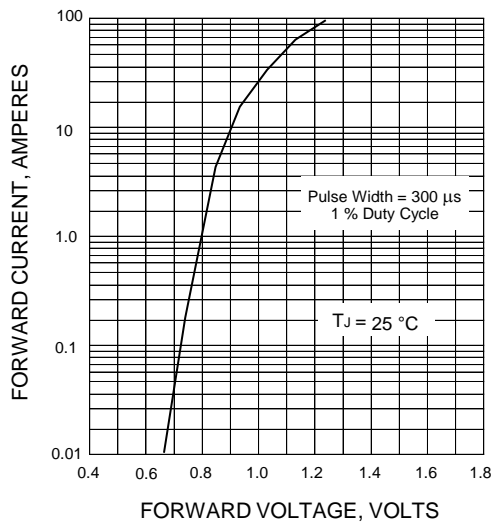

**FIG.4 - TYPICAL REVERSE CHARACTERISTICS PER DIODE**

